



奧冠教育中心

OLYMPIAD CHAMPION EDUCATION CENTRE

Room 309-310, 8 Jordan Road, Yau Ma Tei, Kowloon, Hong Kong SAR, CHINA

Tel (852) 3153 2028 / 9310 1240 Fax (852) 3153 2074

Website: www.olympiadchampion.com Email: olympiadchampion@gmail.com



Hong Kong International
Science Olympiad

香港國際科學競賽初賽 2019 - 2020 (香港賽區)

HONG KONG INTERNATIONAL SCIENCE OLYMPIAD

HEAT ROUND 2019 - 2020 (HONG KONG REGION)

中二級 Secondary 2

時限：60 分鐘

Time allowed: 60 minutes

模擬試題

Mock Paper

考生須知：

Instructions to Contestants:

1. 本卷包括 試題 乙份，試題紙不可取走。
Each contestant should have ONE Question-Answer Book which CANNOT be taken away.
2. 本卷共 4 個範疇，每範疇有 5 題，共 20 題，答對得 2 分，空題得 0 分，**答錯倒扣 1 分。**
There are 4 exam areas and 5 questions in each exam area. There are a total of 20 questions in this Question-Answer Book. Two points for correct answers. No points for incorrect answers. **ONE penalty point will be deducted for incorrect answers.**
3. 請將答案寫在 **答題紙** 上。
All answers should be written on ANSWER SHEET.
4. 比賽期間，小學組不得使用計算工具，**中學組可以使用計算工具。**
During the contest, NO calculators can be used for PRIMARY GROUP **but calculators can be used for SECONDARY GROUP.**
5. 本卷中所有圖形不一定依比例繪成。
All figures in the paper are not necessarily drawn to scale.
6. 比賽完畢時，本試題會被收回。
This Question-Answer Book will be collected at the end of the contest.

本試題不可取走。

請將答案寫在

答題紙

 上。

All answers should be written on the ANSWER SHEET.

THIS Question-Answer Book CANNOT BE TAKEN AWAY.

未得監考官同意，切勿翻閱試題，否則參賽者將有可能被取消資格。

DO NOT turn over this Question-Answer Book without approval of the examiner.

Otherwise, contestant may be DISQUALIFIED.

請將答案寫在 答題紙 上。

All answers should be written on the ANSWER SHEET.

選擇題 (第 1 至 20 題) (答對得 2 分, 空題得 0 分, 答錯倒扣 1 分)

Multiple Choice Questions (1st ~20th) (Two points for correct answers. No points for incorrect answers. **ONE penalty point will be deducted for incorrect answers.**)

Physics

物理

- A jet of water travelling at a velocity of 20 ms^{-1} hits a wall normally. Calculate the pressure on the wall if the water does not bounce back. (Density of water (ρ) = $1.0 \times 10^3 \text{ kgm}^{-3}$).
A. $8.0 \times 10^5 \text{ Pa}$
B. $4.0 \times 10^5 \text{ Pa}$
C. $2.0 \times 10^5 \text{ Pa}$
D. $2.0 \times 10^{-4} \text{ Pa}$
E. $1.0 \times 10^5 \text{ Pa}$
- The rate of heat conduction is proportional to the cross-sectional area and temperature gradient (temperature difference per unit length). On a typical day during the World Cup tournament in South Africa, the air in a room is heated to 25°C while the air outside is -2°C . The area of the window of the room is 2 m^2 and it is made of crown glass with thickness 2 mm and thermal conductivity $1.0 \text{ WK}^{-1}\text{m}^{-1}$. What is the heat power loss through the window?
A. 1.2 kW B. 2.7 kW C. 27 kW D. 50 kW E. Cannot be calculated
- The ratio of radii of two planets P and Q is x and the ratio of their mean densities is y . Find the ratio of the acceleration of free fall on P to that on Q in terms of x and y .
A. $\frac{x}{y}$ B. x^2y C. $x+y$ D. xy E. None of the above
- Given that the universal gravitational constant, $G = 6.7 \times 10^{-11} \text{ Nm}^2\text{kg}^{-2}$ and that the mass, M of the earth is $6.0 \times 10^{24} \text{ kg}$, find the speed of a satellite that is fixed to permanently focus on the city for broadcast of a competition.
A. $3.08 \times 10^3 \text{ ms}^{-1}$
B. 24 ms^{-1}
C. 40 ms^{-1}
D. $3.66 \times 10^3 \text{ ms}^{-1}$
E. Cannot be calculated
- The surfaces of a biconvex lens have radii of curvature of 0.10m and 0.15m. Given that $\frac{1}{f} = (n-1) \times \left(\frac{1}{r_1} + \frac{1}{r_2}\right)$ and the refractive index of the glass is 1.5, find the power of the lens, correct to two significant figures:
A. -8.3D B. -1.7D C. 1.7D D. 8.3D E. Cannot be calculated

請將答案寫在

答題紙

 上。

All answers should be written on the ANSWER SHEET.

Biology
生物

6. It is often possible to measure the amount of air normally present in the respiratory system and the rate at which ventilation occurs. The maximum amount of air that can be forcibly inhaled and exhaled from the lungs is called the vital capacity. The amount of air normally inhaled and exhaled with each breath is called the tidal volume. The residual volume is the air that always remains in the lungs after maximum forced exhalation, preventing the alveoli from collapsing. The expiratory reserve volume is the volume of air that can still be forcibly exhaled following a normal exhalation.

The total lung capacity will be equal to,

- A. Tidal volume plus expiratory reserve volume
 - B. Vital capacity plus expiratory reserve volume
 - C. Vital capacity plus residual volume
 - D. Residual volume plus expiratory reserve volume.
 - E. None of the above
7. Which of these is true of mountain dwellers in relation to people residing at sea level?
- A. Mountain dwellers have greater vital capacity and enlarged thoracic cavity
 - B. Mountain dwellers have reduced vital capacity and compressed thoracic cavity
 - C. Mountain dwellers inhale a smaller amount of air than people living at sea level
 - D. Mountain dwellers have a reduced concentration of red blood cells compared to people living at sea level.
 - E. None of the above
8. As an adaptive mechanism desert animals must conserve water by all means. The kidneys regulate the concentration of salt and water in the blood through the formation and excretion of urine. The kidney is composed of approximately one million units called nephrons. The kidneys of desert animals have modified nephrons which help them survive long periods without water. Which of these options best describes the expected modification?
- A. A short collecting duct
 - B. A very long loop of Henle
 - C. A very short distal tubule
 - D. A large Bowman's capsule

請將答案寫在 **答題紙** 上。

All answers should be written on the ANSWER SHEET.

E. None of the above

9. The amount of DNA present per cell at different stages during several nuclear divisions is represented in Figure 1.

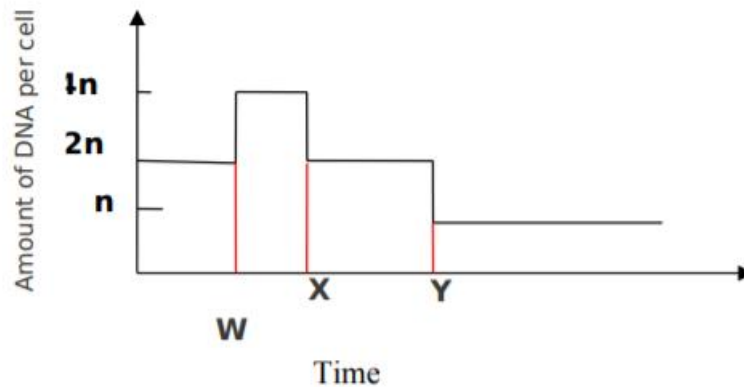

Figure 1: Variations in DNA content of cell

What type of nuclear division is represented by Figure 1 above ?

- A. Mitosis
 - B. Meiosis
 - C. Cytokinesis
 - D. None of the above
 - E. All of the above
10. By using Figure 1, what stages are represented by the lines W, X, Y?
- A. Interphase , telophase I, telophase II.
 - B. Interphase , prophase, telophase II
 - C. Prophase , Interphase, telophase I
 - D. Interphase, anaphase, telophase I
 - E. None of the above

請將答案寫在 **答題紙** 上。

All answers should be written on the ANSWER SHEET.

Chemistry

化學

11. A zinc metal sample containing zinc chloride as impurity was made to react with an excess of dilute hydrochloric acid at 27°C . Liberated hydrogen gas is collected at 760 mm Hg pressure that occupies 780.0 cm^3 volume. If the vapour pressure of water at 27°C is 14 mm Hg, what is the volume of H_2 at STP? The Standard pressure is 760 mm Hg (molar volume of gas at standard temperature and pressure, $\text{STP} = 22.4\text{ dm}^3$)
- A. 746 cm^3 B. 697 cm^3 C. 750 cm^3 D. 300 cm^3 E. Cannot be calculated
12. A compound containing carbon 53.10%, hydrogen 15.95% and nitrogen was found to have a molecular weight of 90 g/mol (C = 12 g/mol; H = 1g/mol; N= 14 g/mol). The molecular formula is
- A. $\text{C}_4\text{H}_{14}\text{N}_2$
B. $\text{C}_2\text{H}_7\text{N}$
C. $\text{C}_3\text{H}_{12}\text{N}_2$
D. $\text{C}_2\text{H}_{14}\text{N}_2$
E. None of the above
13. By using Figure 3, when the switch is closed, the bulb in the set up above will light if:

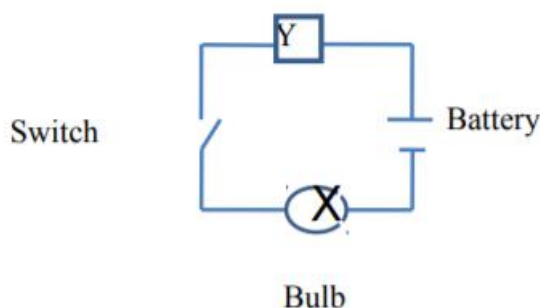

Figure 3: Electric circuit

- A. Y is section of an orange fruit
B. Y is a section of dried avocado pear
C. Y is distilled water

請將答案寫在 答題紙 上。

All answers should be written on the ANSWER SHEET.

D. Y is a beaker of 95% ethanol

E. None of the above

14. For the oxidation–reduction reaction;

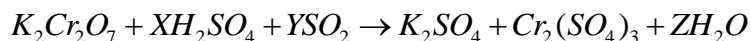

The values X, Y and Z are:

A. 1,3,1

B. 4,1,4

C. 3,2,3

D. 2,1,2

E. 1,2,1

15. Biochemists have discovered more than 400 mutant varieties of haemoglobin, the blood protein that carries oxygen throughout the body. A physician studying a variety of haemoglobin associated with a fatal heart disease first finds its molar mass (M). She dissolves 21.5 mg of the protein in water at 5.0°C to make 1.50 cm³ of solution and measures an osmotic pressure of 0.00475 atm. What is the molar mass of this haemoglobin variety? [R = 0.0821 l–atm mol⁻¹ K⁻¹]. Osmotic pressure (π) = CRT

A. 6.89×10⁴ g mol⁻¹

B. 7.89×10⁴ g mol⁻¹

C. 8.88×10⁴ g mol⁻¹

D. 6.47×10⁴ g mol⁻¹

E. Cannot be calculated

請將答案寫在 答題紙 上。

All answers should be written on the ANSWER SHEET.

Integrated Science

綜合科學

16. In using an axe to split firewood, the following energy forms are involved
- (i) Chemical (muscle) energy
 - (ii) Mechanical potential energy of the axe;
 - (iii) Chemical (binding) energy of wood, heat energy, sound energy and kinetic energy of wood fragments;
 - (iv) Mechanical kinetic energy of the axe.

Which is the most likely sequence of the energy exchanges?

- A. (i), (ii), (iv), (iii)
 - B. (i), (iv), (iii), (ii)
 - C. (iv), (i), (ii), (iii)
 - D. (i), (ii), (iii), (iv)
 - E. None of the above
17. The Doppler principle refers to a difference in frequency observed due to the relative motion of the observer and the moving source. Speed limit violators are usually monitored by the use of a radar gun which releases microwaves on the moving vehicle in short bursts. By applying the Doppler principle, the difference (Δf) between the frequency of the microwave emitted by the radar gun and that reflected by the moving vehicle (and received by the gun) is obtained. The velocity (v) of the vehicle is then determined. If Δf is 2667 Hz and the frequency of the microwave is 1.0×10^{10} Hz, obtain the speed of the car.
- A. 160 ms^{-1}
 - B. 80 ms^{-1}
 - C. 40 ms^{-1}
 - D. 27 ms^{-1}
 - E. Cannot be calculated
18. A gas X at 1atm is bubbled through a solution containing a mixture of $1 \text{ M } Y^-$ and $1 \text{ M } Z^-$ at 25°C . If the order in the electrochemical series is $Z^- > Y^- > X$ then
- A. Y^- will oxidize X and not Z^-
 - B. Y^- will oxidize Z^- and not X
 - C. Y^- will oxidize both X and Z^-

請將答案寫在

答題紙

 上。

All answers should be written on the ANSWER SHEET.

D. Y^- will reduce both X and Z

19. For any animal to survive in water, it must devise a means of obtaining oxygen for respiration. Fishes, for instance, obtain oxygen dissolved in water through their gills.

Which of the following way(s) is (are) correct as sources of oxygen for aquatic insects?

i. Atmosphere

ii. Oxygen dissolved in water

iii. Air-containing cavities of submerged aquatic plants

A. iii

B. i, ii

C. i, ii, iii

D. ii, iii

E. None of the above

20. Certain environmental conditions such as availability of water, optimum temperature and oxygen, must be present before the embryo of a seed will grow. Sometimes light is required for the seed to germinate. Seeds which require a stimulus of light for germination are usually relatively small. Which of following best explains the significance of this?

A. Small seeds commonly require light before germination will occur.

B. Small seeds commonly require light to inactivate the growth inhibitors in its coat before germination.

C. Small seeds have relatively small food reserves; it is therefore important that growing shoot reaches light quickly so that photosynthesis can start before the reserves are exhausted.

D. Small seeds commonly require light to find a suitable place for germination.

E. None of the above

~ 全卷完 ~
~ End of Paper ~